

Kwik-Till

High Speed Tillage
New - Maintenance Free



NORWOOD
Sales Inc.

10-15 mph



Tri-Fold
25'-45'



Rigid
8'-12'



Bi-Fold
16'-24.5'

Till up to 75
acres per hour



ACKERMANDISTRIBUTING.COM 800-726-9091

TRI-FOLD KWIK-TILL

MODEL	(A) TRANSPORT HEIGHT	(B) TRANSPORT LENGTH	(C) TRANSPORT WIDTH	(D) UNFOLDED LENGTH	(E) UNFOLDED WIDTH	WEIGHT	TRANSPORT TONGUE WT.	TIRE SIZE WING	# OF DISCS
HSD2500	13'-2"	22'-11"	13'-0"	27'-6"	26'-9"	21,100	3,400	600/50R22.5	60
HSD3000	13'-6"	22'-11"	13'-0"	27'-6"	31'-5"	23,100	4,500	600/50R22.5	72
HSD3500	13'-1"	28'-6"	15'-11"	33'-5"	36'-5"	28,100	5,200	600/50R22.5	80
HSD4000	13'-4"	28'-6"	15'-11"	33'-5"	41'-5"	31,400	6,800	600/50R22.5	96
HSD4500	13'-6"	29'-9"	18'-0"	34'-9"	46'-5"	35,400	7,700	600/50R22.5	108

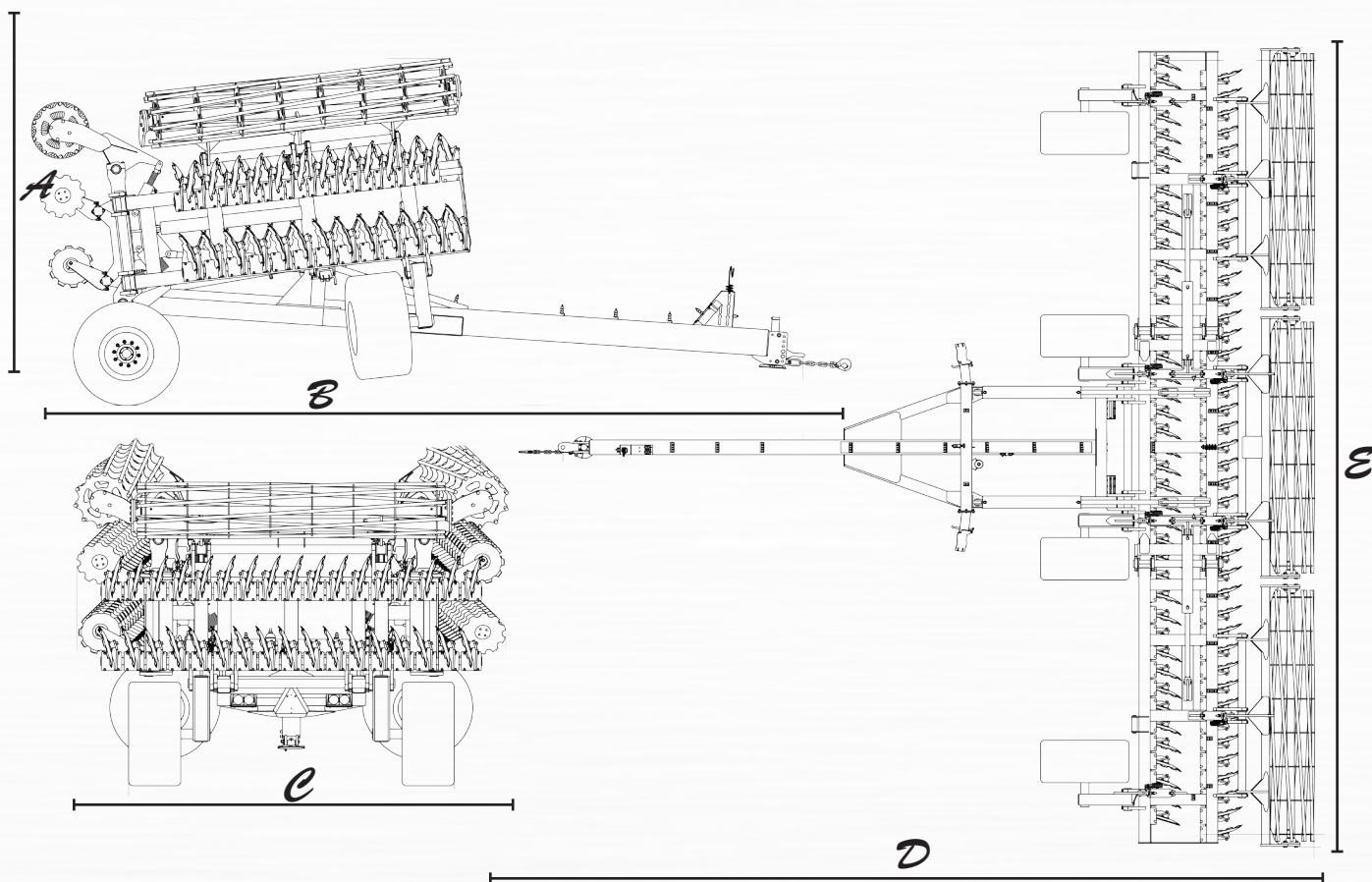

TRI-FOLD TRANSPORT PROCESS



BI-FOLD KWIK-TILL

MODEL	(A) TRANSPORT HEIGHT	(B) TRANSPORT LENGTH	(C) TRANSPORT WIDTH	(D) UNFOLDED LENGTH	(E) UNFOLDED WIDTH	WEIGHT	TRANSPORT TONGUE WT.	TIRE SIZE WING	# OF DISCS
HSD1600 BI-FOLD	12'-5"	22'-1"	12'-5"	27'-6"	17'-0"	15,020	1,800	600/50R22.5	38
HSD1775 BI-FOLD	12'-6"	22'-1"	12'-5"	27'-6"	18'-8"	15,600	2,000	600/50R22.5	42
HSD2100 BI-FOLD	12'-8"	22'-1"	12'-5"	27'-6"	22'-0"	16,800	2,600	600/50R22.5	50
HSD2400 BI-FOLD	12'-11"	22'-1"	12'-5"	27'-6"	25'-4"	17,800	3,200	600/50R22.5	58

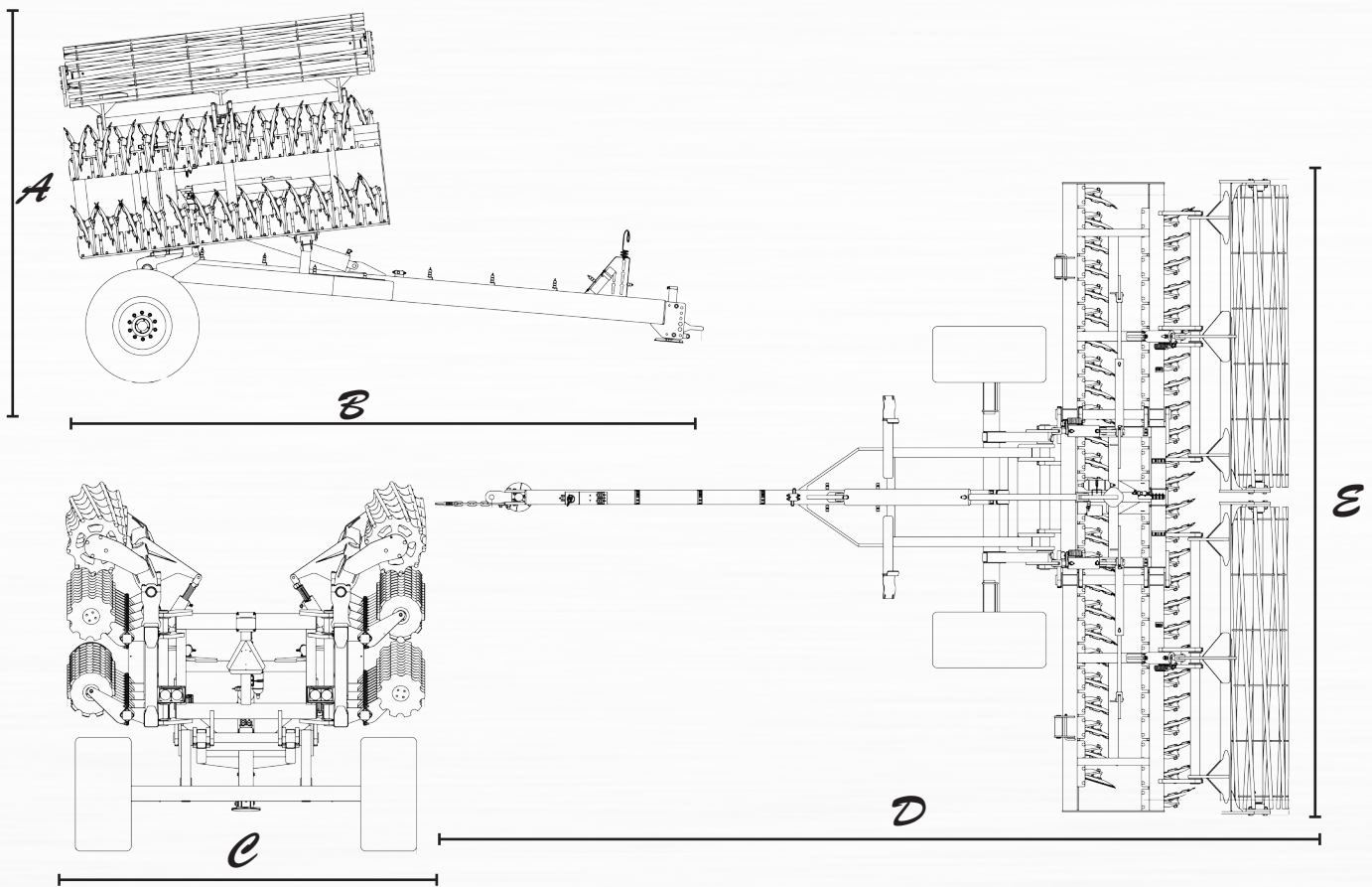

BI-FOLD TRANSPORT PROCESS

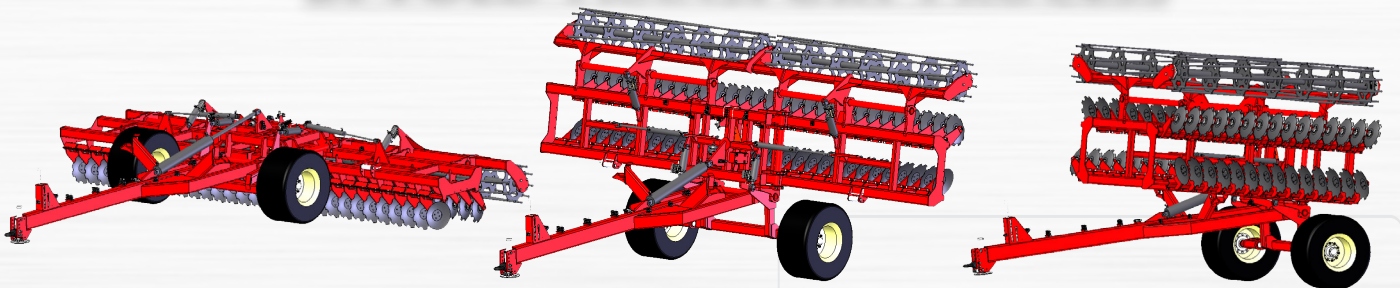

MONO-FOLD KWIK-TILL

MODEL	(A) TRANSPORT HEIGHT	(B) TRANSPORT LENGTH	(C) TRANSPORT WIDTH	(D) UNFOLDED LENGTH	(E) UNFOLDED WIDTH	WEIGHT	TRANSPORT TONGUE WT.	TIRE SIZE WING	# OF DISCS
HSD800	10'-1"	15'-4"	9'-3"	20'-2"	9'-3"	7,325	1,370	380/60R16.5	20
HSD1000	10'-1"	15'-4"	10'-11"	20'-2"	10'-11"	8,020	1,500	380/60R16.5	24
HSD1200	10'-1"	15'-4"	12'-7"	20'-2"	12'-7"	8,460	1,580	380/60R16.5	28
HSD800 3 Point	10'-1"	8'-3"	9'-3"	8'-3"	9'-3"	4,800			20
HSD100 3 Point	10'-1"	8'-3"	10'-11"	8'-3"	10'-11"	5,010			24
HSD1200 3 Point	10'-1"	8'-3"	12'-7"	8'-3"	12'-7"	5,950			28

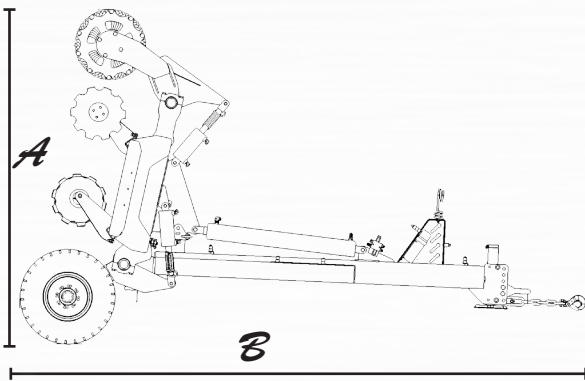

3 Point Hitch

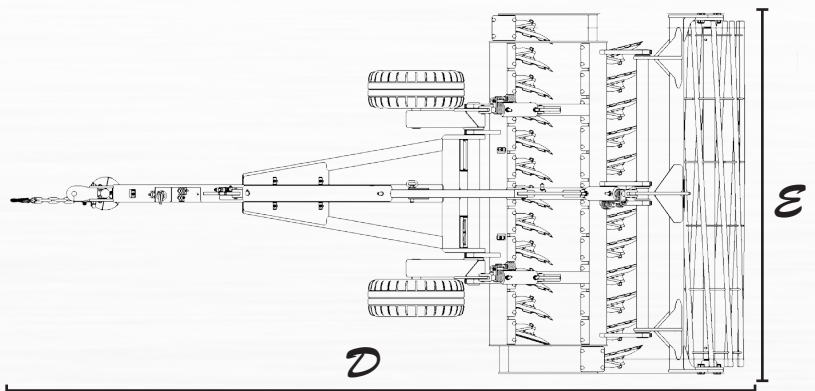
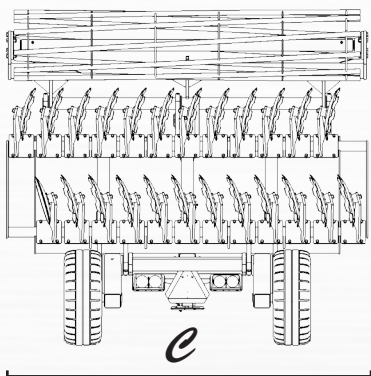
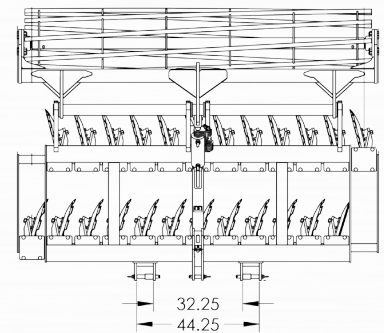

MONO-FOLD TRANSPORT PROCESS

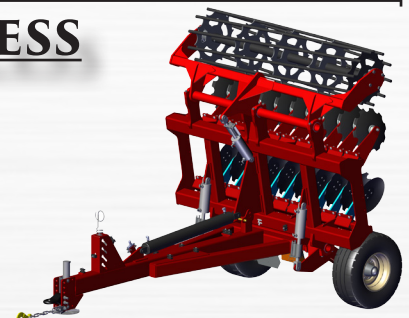

STANDARD FEATURES

- 20" disc with a choice of Notch Disc or Plain Flat Disc
- Goodyear 600/50R22.5 Tires (2/per Bi-Fold - 4/per on Section Machines).
- 17° front row angle, 14° back row angle, 10" spaced independent shank.
- Powder Coat Options (Red or Green)
- SKF AgriHub - Maintenance Free Hub Bearing
- Cage roller rear basket
- Hydraulic Jack

CAGE/SPRING BASKET/RUBBER ROLLER

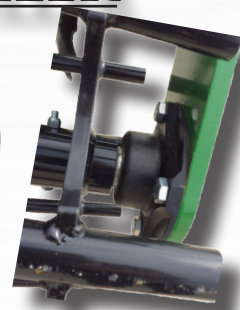
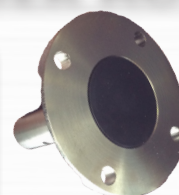

Maintenance Free,
quadruple
protected hub

CAGE ROLLER (standard): works best in dry, non-sticky soil conditions. The cage design ensures disintegration of any clumps, provides an even seedbed and moderate compaction.



SPRING PACKER (optional): works best in heavier dense soil. The spring packer creates a level seedbed with moderate consolidation.



RUBBER ROLLER (optional): an all around excellent roller, suitable for any type of soil or soil conditions and offers very good consolidation.



SUPERFLOAT AG TIRES



Unsurpassed flotation that has a large contact area. Makes for excellent weight distribution for reduced ground-bearing pressure and less soil compaction.

HYDRAULIC JACK



Provides quick, easy disconnection from tractor. Lifts vertically without moving machine backward and forward. Designed with less moving parts for a simpler more reliable operation.



ACCUMULATOR



The accumulator is used in conjunction with a cross over relief valve to protect the wing cylinders from damage. Helps prevent damage by overextending cylinders or if the float position is forgotten to be put in place before use.

RUBBER TORSION SUSPENSION SYSTEM

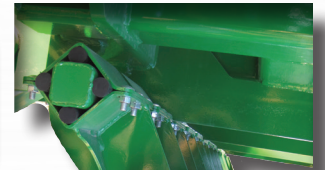

Four natural rubber elements provide a pretension, allowing the discs to follow the contour of the land. Skating over obstructions and springing back to operating position. Each shank is independent, allowing for ideal flow of residue.

BUSHING

Nylon bushings replace greased steel on steel pins at all pivot points. They provide a long service life and eliminates daily greasings.

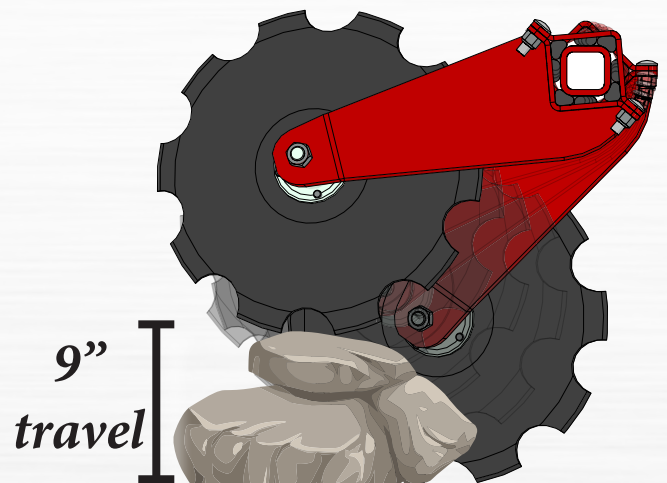
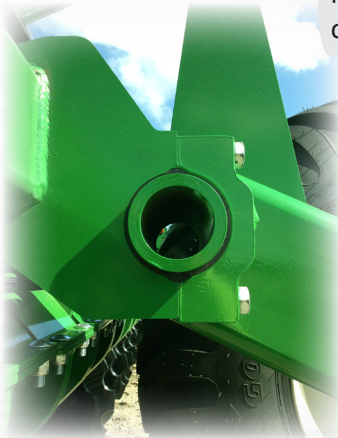

DISCS



20" Plain Flat Center Disc Blade

Plain flat center discs have a slight concavity to provide careful control over soil tillage. The disc option does an excellent job tilling and inverting soil. Action of this disc varies depending on speed.

20" Notched Shallow Concave Disc

Notched discs provide an aggressive control over soil tillage. The shallow concavity and vertical design of the disc allows for great tillage of the lower soil levels while not compacting the top soil.



CYLINDERS AND STOPS



- Helps control depth into the ground.
- Located right on the cylinders.
- Can be set in half inch increments

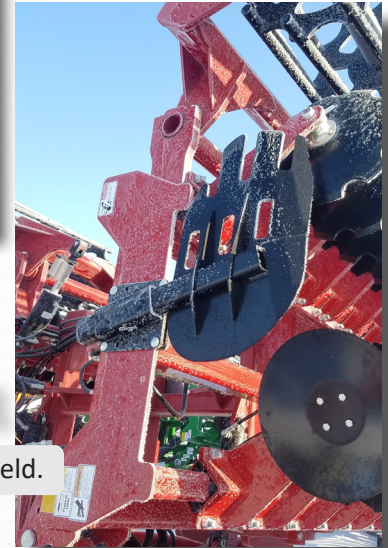

DEFLECTOR

Reduces ridging in the field.

MAINTENANCE FREE GREASELESS HUB

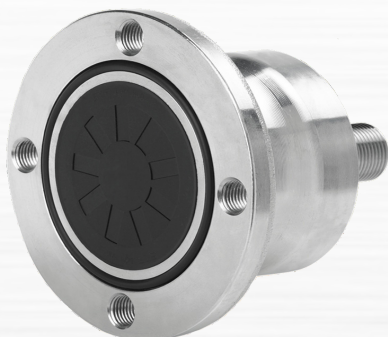

Relubrication-free: integrated solution increases farm productivity. Suitable for virtually any agricultural implement arm, the SKF Agri Hub for tillage discs is a robust, easy fit hub sealing solution. The unit features a flanged outer ring that is pre-drilled and tapped to accommodate a disc. A stationary inner ring fitted with a threaded stub shaft helps ensure fast, easy mounting.

Extensive lab and field tests reveal that SKF Agri Hub for independent tillage discs can deliver several benefits for OEMs and end users alike.





NORWOOD

Sales Inc.

Kwik-Till

High Speed Tillage

ACKERMAN INC.
SINCE 1969
DISTRIBUTING.COM
800-726-9091



ACKERMANDISTRIBUTING.COM 800-726-9091